

Spid Rotator and Controller **Instruction Manual**

WWW.RFHAMDESIGN.COM



Table of Contents

Introduction.....	3
Shipping Contents	3
Technical Data	3
Control Panel.....	4
Rear Panel	5
Installation	6
Wiring Connections.....	6
Bench Testing	7
Resetting the Controller.....	8
Controller Operation	9
Function Mode	9
Normal Operations Mode.....	9
Half Auto Mode	9
Auto Mode	10
Setup Mode	10
Programable High Limit	10
Programmable Low Limit	10
Mouse Controller	12
Spid Log Demo Software.....	13
Using the AlfaSpid Rotator with LONG Cable Distances	14

Introduction

The AlfaSpid rotator is an extra heavy-duty rotator designed to run large communication antennas and comes complete with an electronic control unit. The rotator is designed to be mounted pipe to pipe or on an optional adaptor plate for conventional in tower mounting. It can also be mounted outside of the tower on the mast, or used in a side mount configuration.

Shipping Contents

Rotator.....	1
Controller.....	1
Serial(RS232) Interface Cable.....	1
CD-ROM (Utilities and Demo Logging Program).....	1
GMA-8 Fuses	2
Custom Mouse	1



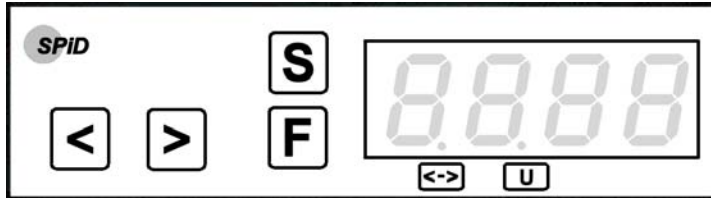

Technical Data

Input Voltage (Typical).....	12 – 24 Volts DC
Input Current (Nominal Draw).....	2 – 3 Amps
Motor	12 – 24 Volts DC
Fuse	8.0 Amp GMA
Rotation Speed.....	120 sec (12 V) / 60 sec (24 V)
Turning Torque (in-lbs).....	1400 (12 V) / 1740 (24 V)
Braking Torque (in-lbs).....	> 14,000



Control Panel



Buttons

-  -Up (Decrease)
-  -Down (Increase)
-  -Setup
-  -Function

Indicators

-  -Overlap
-  -Not currently used

7 segment 4-digit display

 - Multifunction display

Rear Panel

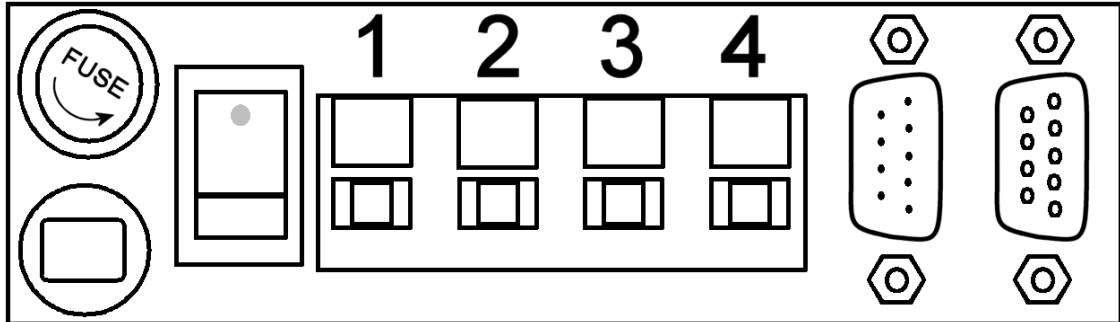

or

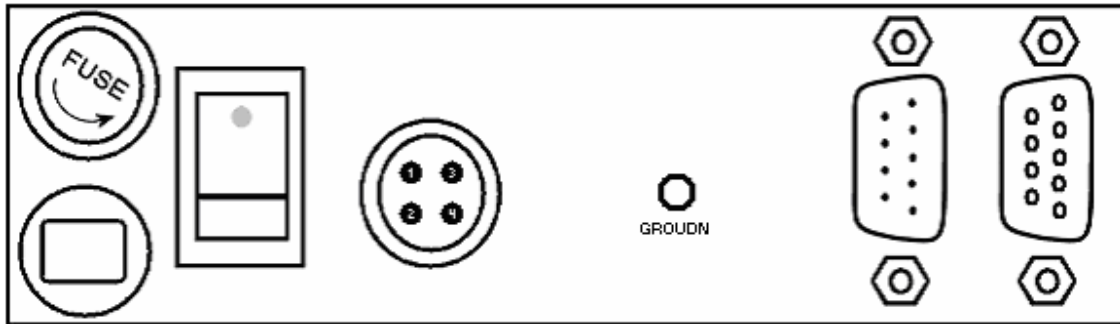

-Fuse Holder



- Power Cord

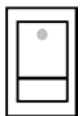

- Power Switch

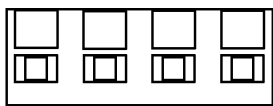

or



- Terminal Strip



-DB-9 connector (male)



-DB-9 connector (female)

Installation

Wiring Connections

The rotator unit must be wired to the control unit with 4-wire cable. The gauge of the 4-wire cable to connect the control unit to the rotator depends upon the distance between rotator and controller. The wire for the impulse sensing may be quite thin - #22 or similar, even for relatively long distances.



TIP:

Before final installation of equipment, it is strongly suggested you check out all functions and connections on a workbench.

Length

10 m (32')

30 m (100')

60 m (200')

Gauge Motor

#18 (1.19 mm)

#16 (1.42 mm)

#14 (1.75 mm)

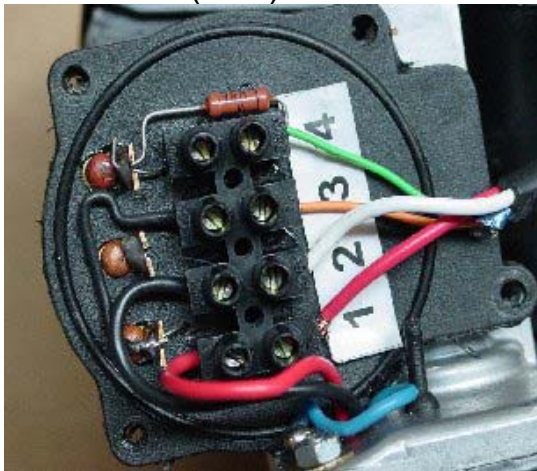

CAUTION!:

Do not accidentally switch the motor wires with the impulse wires. Damage to the control unit may occur!

Remove cover from the motor body as shown and make connections as follows:

- 1 Motor Drive to 1 on controller terminal
- 2 Motor Drive to 2 on controller terminal
- 3 Impulse Sense to 3 on controller terminal
- 4 Impulse Sense to 4 on controller terminal

Bench Testing of Control Box

The control box is normally expected to be operated from a 12 Volt DC supply, however it may be operated from other unregulated DC or AC sources as well. DC or AC voltage levels between 10 and 26 Volts capable of at least 5 Amps are acceptable, typically 12 or 14 Volts.

*The polarity of the power to the control box input leads is **not critical**, as a full wave bridge rectifier on the input will provide the proper polarity to the electronics.*

TIP: *Because of several steering diodes in the motor path, the voltage delivered to the motor (neglecting wire loss) will be about 1.4 volts less than the power supply voltage. For longer runs and/or thin wiring a higher voltage (up to approx 26VDC) to the control unit is beneficial. A simple way to estimate if the voltage to the motor is adequate is by timing the rotation. Under no or a very small load, the 360 degree rotation time with 12V DC at the motor is about 120 second (2 minutes). With 24 V DC is about 60 second (1 minute). A DC Ammeter in the motor lead is also useful, it should indicate between 1 and 3 amps with a small load. On windy days or heavy load, the current may fluctuate up to 3 to 5 amps.*



It is highly recommended to ground the Control Box.

Notes – testing and troubleshooting

Pressing should make the rotator move clockwise. Pressing should make the rotator move counter-clockwise. If rotation is reversed, switch lines 1 and 2 on the back of the controller. Impulse sense lines (3 & 4) have no polarity concerns.

Part of the overload protection circuitry involves removing motor power if the controller receives no sense indication. If the motor turns for a few seconds and then you hear the relay in the control box drop out, the motor has either stalled or there is a problem in the impulse sense wiring.

Resetting the Controller

Since there are no mechanical limits in the rotator, it may be installed with the antenna pointing in any direction. There is no reason to locate “TRUE NORTH” until you are ready to calibrate the control box. Use the controller to position the antenna to physically point north, then reset the controller as follows:

Turn the unit OFF.

While holding the **[F]** button depressed turn control unit back on. This will now show **8888** on the display. The controller is now set for North. The display may also show **5888** – press the **[F]** button to cycle thru to the normal (i.e. blank) setting.

This feature can be used if, for any reason, the direction of the antenna becomes incorrect. This may be caused by antenna to mast slippage or incorrect initial alignment.

IMPORTANT:

The AlfaSpid rotator is now set at the counter-clockwise end of its normal rotation range. Normal rotation range is in a clockwise direction for 360 degrees.

From the reset position, you can rotate counter-clockwise an additional 180 degrees in over-travel, as well 360 degrees clockwise, plus an additional 180 degrees into clockwise over-travel.

Counter-clockwise over-travel is indicated by a steady dot above the over-travel icon. **[<->]** Rotation past 359 degrees into the clockwise over-travel is indicated by a blinking dot above the over-travel icon.



Technical Note:

You will need to leave sufficient coax length to accommodate the additional 180 degrees of over-travel on each end of normal rotation. Failure to do so can cause damage to your coax and/or antennas.

Controller Operation

The AlfaSpid controller has multiple modes of operation. You will need to become familiar with these modes to be able to make full use of your rotator.

F Function Mode

The **F** button steps through the function menus. The leftmost character on the display indicates the function mode you are currently in.

8880 - Normal Operations Mode
H880 - Half Auto Mode
A880 - Auto Mode

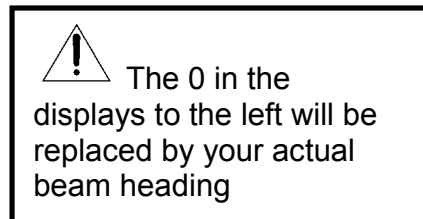

8880 - Normal Operations Mode

In Normal Operations Mode, the **◀** and **▶** buttons cause rotation as long as the buttons are pressed. Pressing **S** while in normal operations mode will take you to setup mode.

H880 - Half Auto Mode

In Half Auto Mode, the **◀** and **▶** buttons can be used to pre-select the desired beam heading. The heading displayed on the controller will rapidly change in the direction of desired rotation. Once the desired beam heading is shown on the display, release the key. Approximately ½ of a second after no key presses have been detected, the display will revert back to the actual beam heading, and rotation towards the desired heading will take place. Pressing any key while in transit to the desired heading will cancel the action.

A880 - Auto Mode

In Auto Mode, the controller will respond to commands from control software running on an attached computer. The **<** and **>** buttons can still be used as a manual override.

S Setup Mode

The **S** button steps through the setup menu. The display cycles through each of the setup menu items.

PH88 - Programmable High Limit

PL88 - Programmable Low Limit

PS85 - Program Simulation

8880 - Heading Adjust (numbers blinking)

PH88 - Programmable High Limit

The Programmable High Limit is a user adjustable clockwise travel limit value. By reducing this value, the maximum clockwise rotation travel can be restricted. Use the **<** and **>** buttons adjust the value.

PL88 - Programmable Low Limit

The Programmable Low Limit is a user adjustable counter-clockwise travel limit value. By increasing this value, the minimum counter-clockwise rotation travel can be restricted. Use the **<** and **>** buttons adjust the value.

These limits can be used when side mounting the rotor to keep the antenna from colliding with the tower.

PS85 - Program Simulation

Program Simulation allows the user to set the serial communication protocol used by the rotator. When set to emulate another brand of rotator, the AlfaSpid will respond to commands, and send responses back to the computer as if it were the rotator brand selected. If your favourite software supports a rotator, chances are, the the AlfaSpid will be able to interface to your software. There are 4 modes available:

PS85 - Spid

PS84 - Yaesu

(GS232 protocol, 600N1, 8 bits)

(data rate 600, 1 STOP bit, no even parity bit)



8880 - Heading Adjust (numbers blinking)

This setting can be used to make minor heading adjustments without causing the rotator to turn. If you notice that the heading displayed on the controller to a known signal source is out by a few degrees, you can change the heading displayed on the LED readout to match the known heading, rather than having to turn back to North and reset the controller.

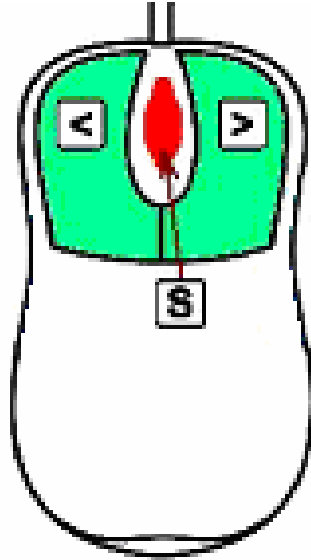
Mouse Controller (Optional)



The optional mouse controller allows easy desktop access to the most commonly used front panel controls. These buttons are functionally equivalent to the corresponding front panel controls.

-  - Up (Decrease)
-  - Down (Increase)
-  - Setup



The mouse controller is a highly modified computer mouse. You can not use a regular mouse with the AlfaSpid rotator nor vice-versa.

The mouse ball serves no function, the mouse simply provides an ergonomically pleasing case in which to mount the controls.

Spid Log Demo Software

The Spid Log software allows you to:

Log QSOs and associated information.

Print QSL labels.

Calculate azimuth and distance from home QTH to entered call sign.

Control rotator direction.

Functions with external call sign databases.

Database sort and report facilities.

Display maps – sun and gray line, coordinates.

Map controllable point and click command of rotator

Alfa Radio Ltd does not support Spid Log, and is provided as a demo package only. Other commercial logging programs support the AlfaSpid rotator; if your favourite software does not, have the author contact us. We will provide the specifications necessary to implement control via software.

Using the Spid Rotator with LONG Cable Distances by VE6JY

Since the motor uses relatively low voltage DC, a combination of long cable runs and/or thinner than required cable may reduce the voltage at the motor to an unacceptably low value. It may turn in warm weather or light winds but the power will not be available to rotate under more severe conditions.

While it is easy to say just use a heavier cable, this may be costly, impractical or both. I have one tower that is over 1700 feet (approx 500 meters away) and running large cable out there would be very expensive.

My solution is to use this rotator controller's output voltage to control another set of relays that will feed a higher voltage DC to the motor. In the above-mentioned example, I find a voltage between 60 to 80 volts gave suitable performance. This is a pretty extreme case but it illustrates the versatility of this design. The external DC supply voltage needed will vary depending on the DC voltage rating of your motor, the cable size and length of the run. Typically 36 to 50 volts at 3-5 amps should be quite adequate. These DC motors are quite tolerant on their voltage ratings.

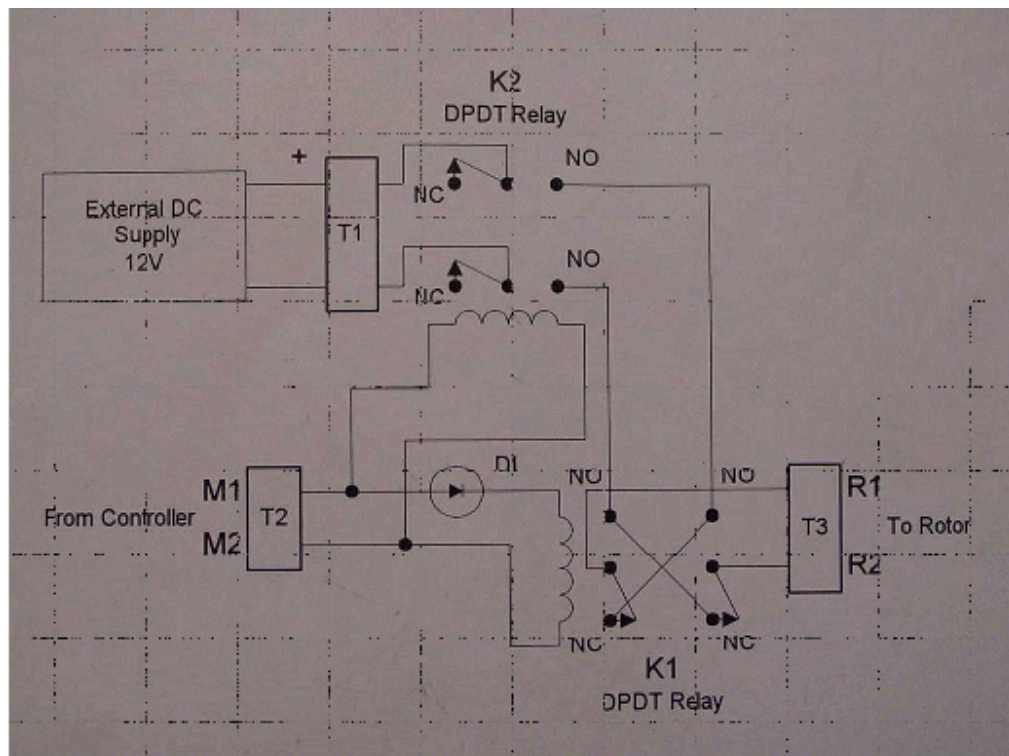

Relay Board Schematic

Relays chosen should be suitable for the proper coil voltage as well as appropriate current carrying capability. A relay capable of 5 to 10 amps DC is adequate. The diode in series with Relay K1 is any general purpose 1 amp style such as the 1N400x series. If the motor rotates incorrectly, simply reverse the leads to the motor or from the External DC Supply.

The controller also has the capability to, with a small modification, allow you to input your external DC voltage into the unit and use the internal relays to control the rotator as usual.

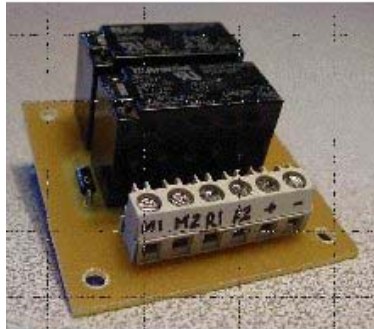

This information is presented as a guide to help the user realize a solution to the long cable run situation.